

HAUSER 2000

JIG GRINDING MACHINE



JIG GRINDING MACHINE

THE BASIC REQUIREMENTS FOR HIGH ACCURACY MACHINE

- Robust, distortion-resistant module
- Consequent lay-out with regard to thermal stability

GUIDEWAYS / MEASURING SYSTEMS / AXES DRIVES

- Sliding guideways wherever required
- Linear guideways wherever possible
- Absolutely smooth stroke reversal
- Measuring systems optimally positioned with regard to the measuring technique
- Axes drives in the centre of friction

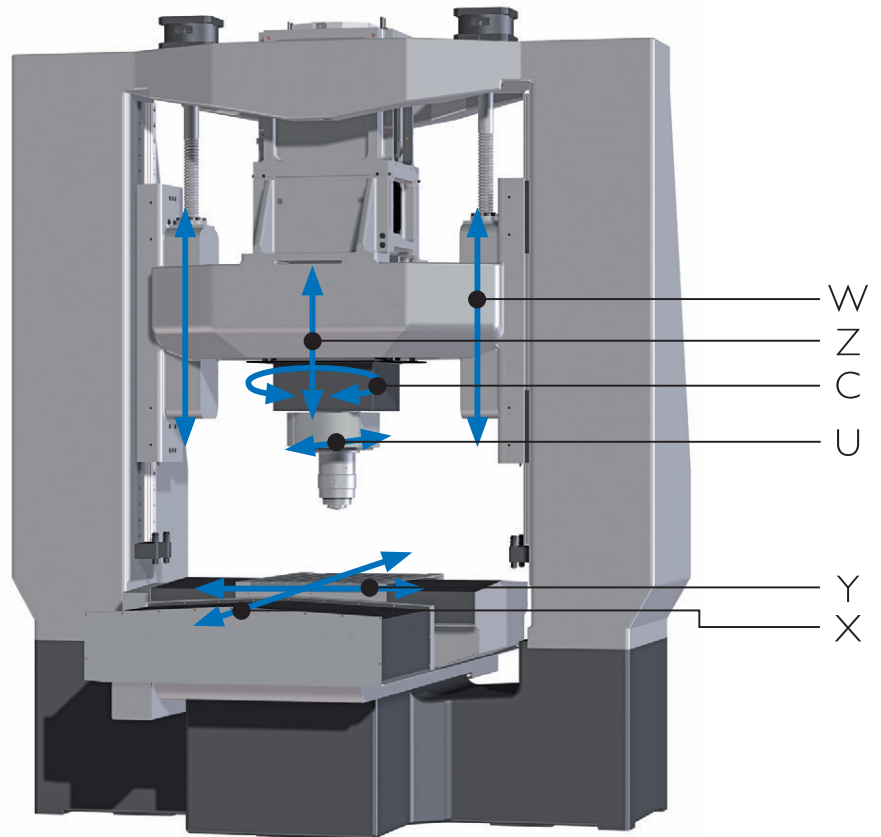

GUIDEWAYS

- Scraped sliding guideways in X and Y axis

MACHINE OPTIONS

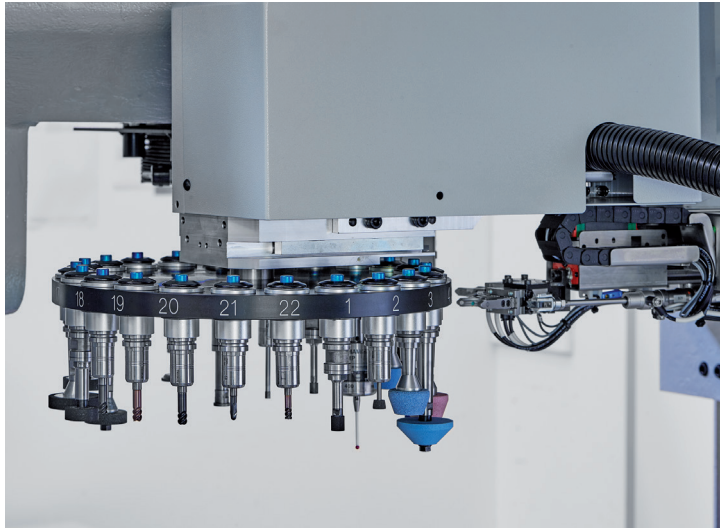

ATC AUTOMATIC TOOL CHANGER

ATC automatic tool changer with 22 magazine positions, permitting automatic machining with grinding wheels from \varnothing 3 mm to \varnothing 50 mm.

Option with Fanuc 30i



GRINDING MOTOR

Grinding motor 70HS ATC with its extremely wide range of application, from 9000 min-1 to 70000 min-1. This grinding motor, and its state of the arts design is an absolute must for getting optimal use out of the grinding tool changer.



CBN DRESSING UNIT

CBN dressing unit with HF drive, for conditioning (dressing) vitrified and resinoid bond CBN grinding wheels.

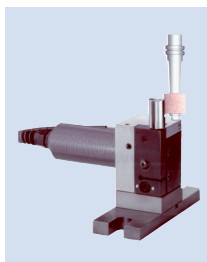

MSS

MSS – multi-sensor-system for automatic suppression of “air grinding” and for automatic grinding wheel calibration.

ROTARY AND ROTARY TILTING AXES

A and A-B axes in customized version are available as additional units.
Option with Fanuc 30i

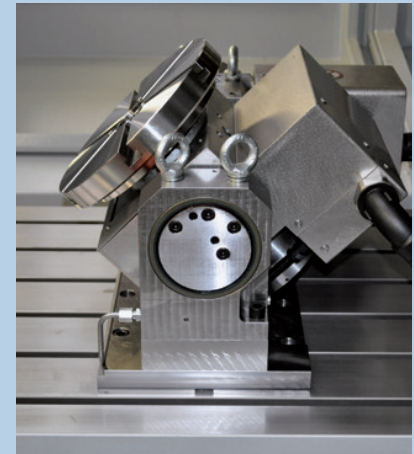

MEASURING PROBE

Measuring probe for the automatic best fit of work-pieces and for the establishment of measuring protocols.
Option with Fanuc 30i



TAPER GRINDING

Automated taper grinding with help of Z-U-axis interpolation.

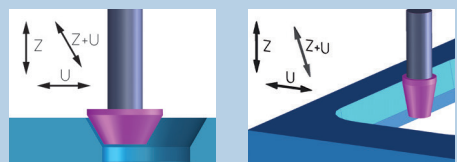

MEASURING SYSTEM

NEW HAUSER JIG GRINDING HEAD

High-grade rigidity and stiffness leads in duplicating the stock removal capability and cuts in half the spark out time.

Allows the combination of grinding and hard milling.

Significant boost in stroke speed and stroke frequency leads into reduced grinding cycle time.

Hydrostatic guided spindle bearing system allows circular accuracies within $< 0.5\mu\text{m}$ in planetary grinding.

Unparalleled U-axis capacity up to +47 mm increases the grinding autonomy.

TECHNOLOGY OVERLAP: JIG GRINDING AND HARD MILLING

Thanks to the most modern grinding head technology, the combination of high accurate jig grinding with complementary hard milling becomes a focal point and is successfully used.



Drive section

Precision section

High-grade rigidity and stiffness leads in duplicating the stock removal capability and cuts in half the spark out time.

Allows the combination of grinding and hard milling.

Significant boost in stroke speed and stroke frequency leads into reduced grinding cycle time.

Hydrostatic guided spindle bearing system allows circular accuracies within $< 0.5\mu\text{m}$ in planetary grinding.

Unparalleled U-axis capacity up to +47 mm increases the grinding autonomy.

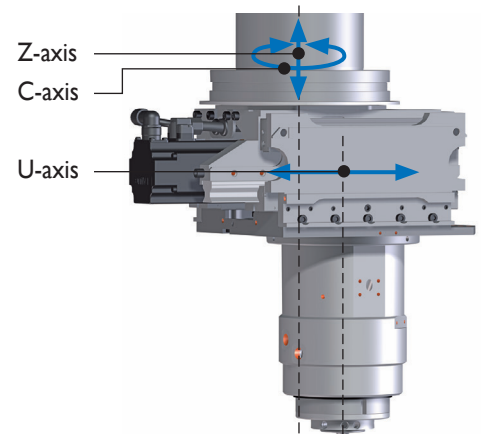
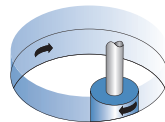

U-axis
Travel capacity = 47 mm

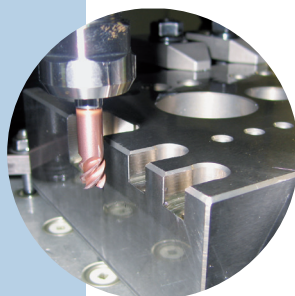
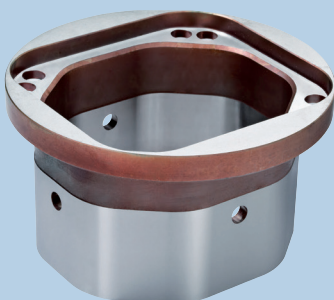

MACHINE CONTROL

CONTROL SYSTEM

If you appreciate user friendly menu programming and insist on the advantages of ISO/DIN programming, then the HAUSER product will be the right choice.

Axis X, Y, C, U, Z and W are CNC controlled, as a standard with Fanuc 30i. With Fanuc 31i the C-axis is an option. Based on these controllers we have created HAUSER-Software cycles, ensuring that the control will perfectly cover all the special requirements of jig grinding

FANUC SERIES 30i

- Max. number of path: 10 - 15 path
- Max. total number of control axes:
- 96 axes (72 feed axes, 24 spindles) / 10 path
- 72 axes (56 feed axes, 16 spindles) / 15 path
- Max. number of simultaneous control axes: 24 axes

The big capability of this model helps to realize an advanced multi axis machine tool. Thanks to a number of control axes, various machining processes can be executed at the same time. Its 5-axis machining function can achieve the machining of complex shape. It has the flexibility to control various types of machine tools.



FANUC SERIES 31i

- Max. number of path: 6 path
- Max. total number of control axes: 34 axes (26 feed axes, 8 spindles)
- Max. number of simultaneous control axes: 4 axes

This is the core model of FANUC CNC with the performance of the world highest level. With abundant functions and high-speed, highly-accurate and high-quality machining technology, it is the most suitable for a high-grade and machining center.



FLOOR PLAN

LEGEND

- 1 location of the operator
- 2 Jig grinder
- 3 workspace protection (cabin)
- 4 electrical cabinet
- 5 CO2 extinguishing agent container
- 6 Coolant system with belt filter automat
- 7 pneumatic group
- 8 hydraulic unit
- 9 heat exchangers
- 10 suction system
- 11 coolant lift tonk
- 12 water coolers
- E electrical connection
- P compressed air connection
- W water connection

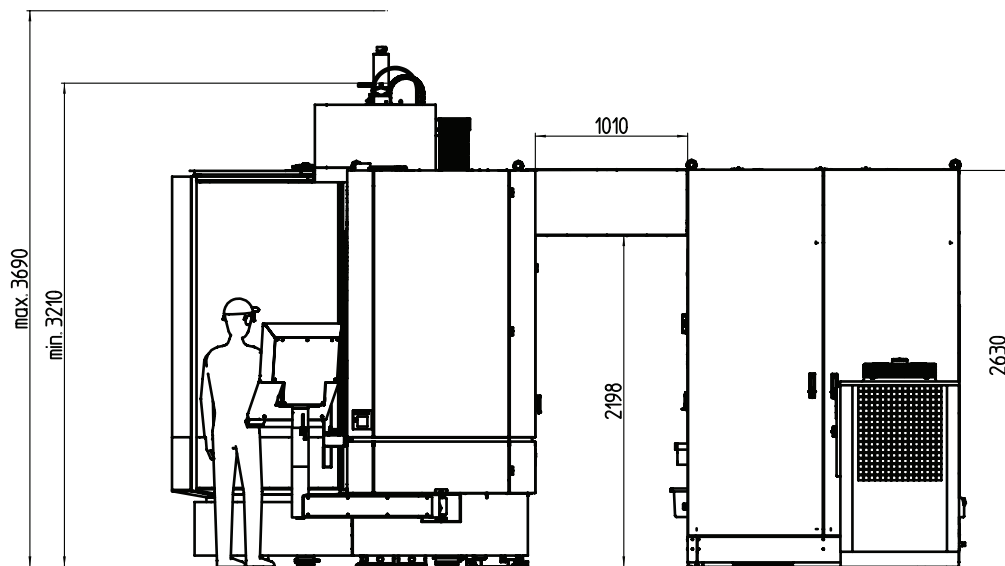

FRONT VIEW

TOP VIEW

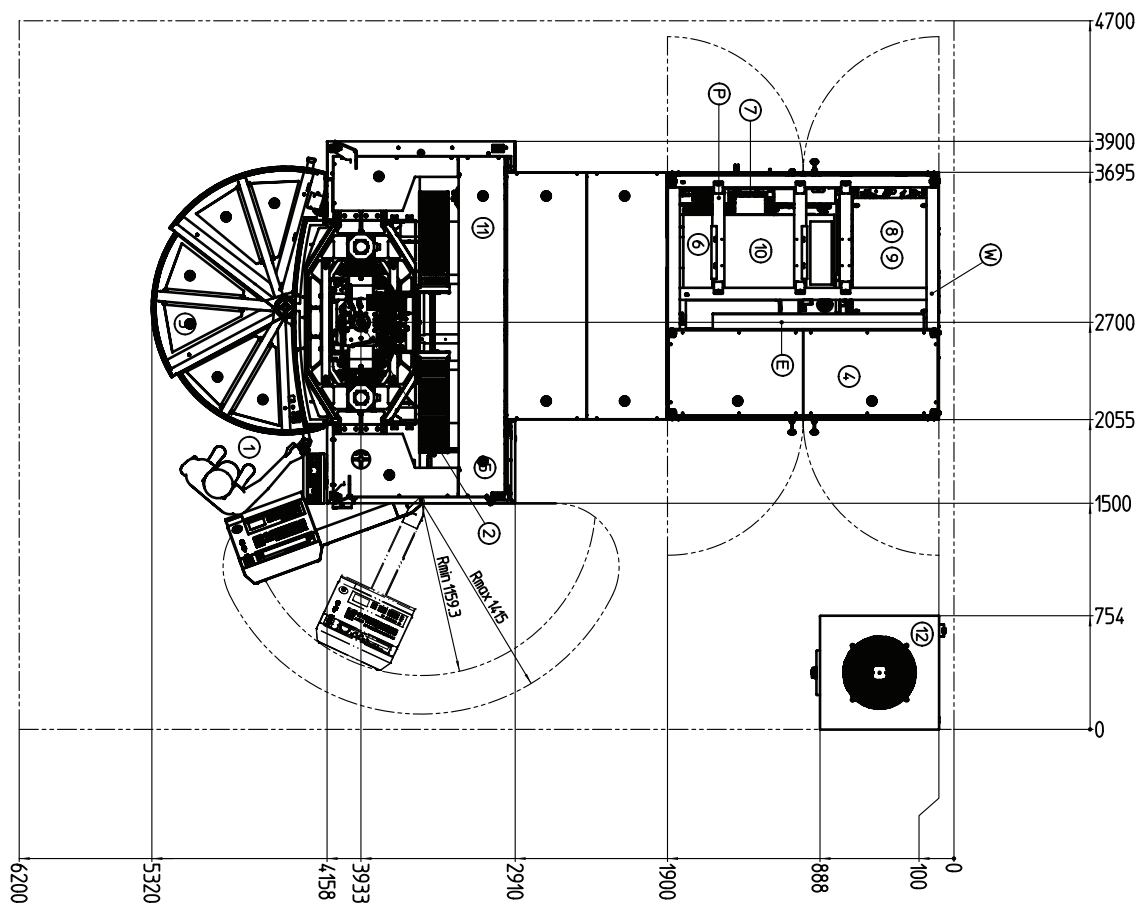

SPECIFICATIONS

Work range		
Range of adjustment X,Y	mm	550×300
Vertical adjustment of grinding head (W)	mm	450
Clearance between table top and U-axis reception face grinding motors	mm	max. 745
Clearance between table top and grinding motor reception nose (70HS)	mm	0–550
Diameter ground in planetary mode, with grinding wheel Ø 50 mm / 70HS:		
• Grinding motor 70HS in U-axis central position, automatic grinding mode	mm	max. 144
• Grinding motor 70HS in U-axis offset position, semi automatic mode	mm	max. 234
• with extension plates	mm	max. 360
Diameter ground in planetary mode, with grinding wheel Ø 100 mm/40HS:		
• Grinding motor 40HS in U-axis central position, automatic grinding mode	mm	max. 194
• Grinding motor 40HS in U-axis offset position, semi automatic mode	mm	max. 284
• with extension plates	mm	max. 360
Taper grinding, included angle, divergent and convergent (Option)	degree	max. 120
Table		
Working surface	mm	650×432
6 T-slots, width	mm	10
Permissible table load	kg	max. 300
Feeds		
Table and saddle X,Y:		
• Machining speed	mm/min	0–4'000
• Traversing speed	mm/min	8'000
Vertical traversing speed W:		
• Machining speed	mm/min	0–4'000
• Traversing speed	mm/min	8'000



Grinding spindle Z, C, U		
Diameter of the spindle sleeve	mm	125
Basic machine is prepared for use of following grinding spindle speeds:		
• For electric grinding motor 40HS, infinitely adjustable and programmable	min-l	4'000 – 40'000
• For electric grinding motor 70HS, infinitely adjustable and programmable	min-l	9'000 – 18'000
• System to activate grinding turbine T15	min-l	150'000
• For electric slot grinding attachment, infinitely adjustable	min-l	3'900 – 18'300
C-axis planetary mode:		
• Planetary mode, infinitely adjustable and programmable	min-l	1–350
• C-axis follow-up mode, AC servo-drive	min-l	up to 10
Z-axis in alternating stroke mode:		
• Z-alternating stroke movement, infinitely adjustable, from mm/min V	min.	0,500
• Z-alternating stroke movement, infinitely adjustable up to mm/min V	max.	26'000
• Z-stroke frequency Hz	max.	10
• Z-stroke length, infinitely adjustable	mm 0,l	bis 170
Z-axis in CNC mode:		
• Z-axis machining speed	mm/min	0–4'000
• Z-axis traversing speed	mm/min	8'000
U-axis radial travel capacity in CNC mode	mm	von -3 up to +47
Accuracy		
Positional uncertainty of the axes X,Y and W, P (corresponding to VDI/DGQ 3441)	mm	0,0015
Planetary grinding accuracy C:		
Achievable roundness accuracy provided max care is taken	mm	0,0005
Room temperature conditions (essential to achieve stated accuracy)		
Ambient temperature	°C	20 -0/+2
Permissible temperature changes	°C	2° per 24 hours, resp. 0,5° per hour
Permissible temperature variations within the machine volume	°C	0,5
Relative humidity	%	25–75
<i>All specifications and designs are subject to alterations without notice</i>		
Control system		
• Control system Fanuc 31i		
• Control system Fanuc 30i		

HARDINGE WORLDWIDE

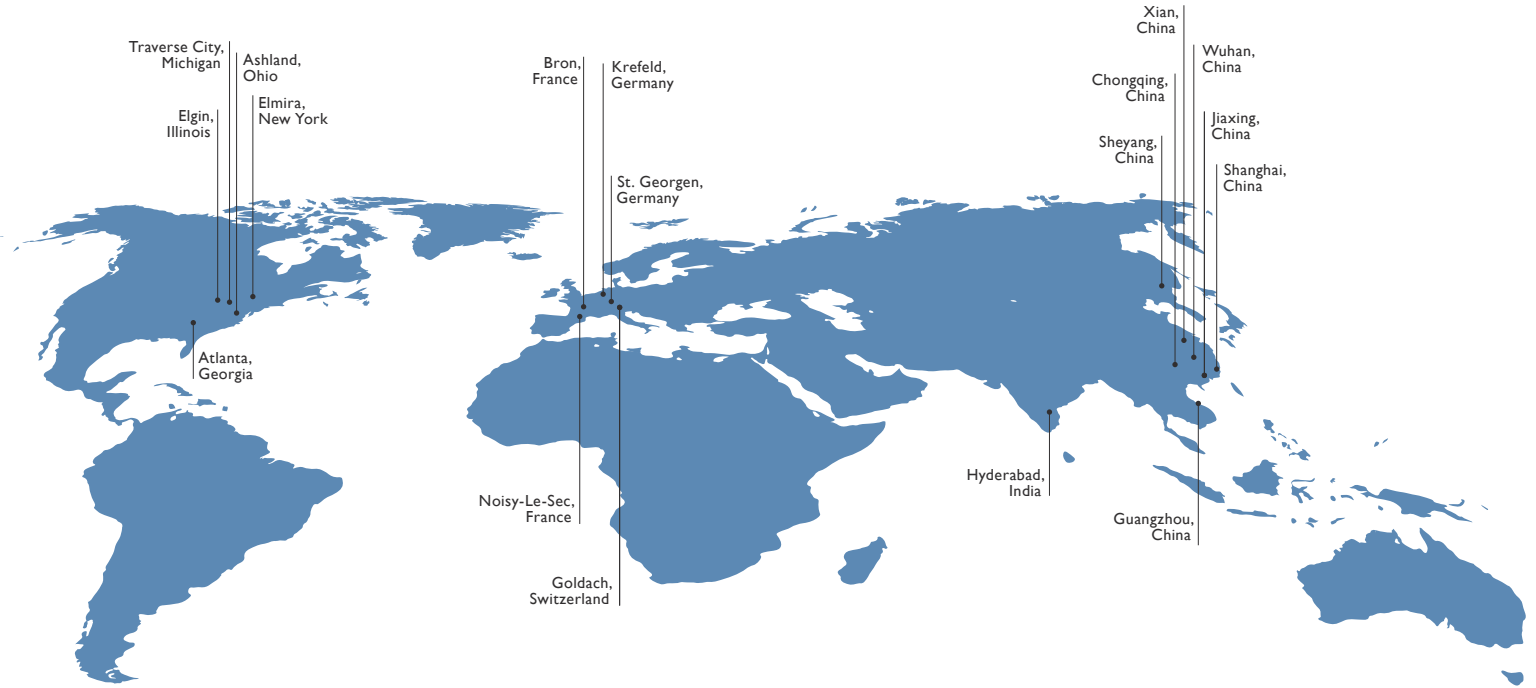

Hardinge is a leading international provider of advanced metal-cutting solutions. We provide a full spectrum of highly reliable CNC turning, grinding, and honing machines as well as technologically advanced workholding accessories.

The diverse products we offer enable us to support a variety of market applications in industries including aerospace, agricultural, automotive, construction, consumer products, defense, energy, medical, technology, transportation and more.

We've developed a strong global presence with manufacturing operations in North America, Europe, and Asia. Hardinge applies its engineering and applications expertise to provide your company with the right machine tool solution and support every time.

AMERICAS

GEORGIA
Hardinge Corporate
79 W Paces Ferry Rd, 2F
Atlanta, GA 30305
P. 800.843.8801

ILLINOIS
Hardinge
1755 Britannia Dr
Unit 1A
Elgin, IL 60124

MICHIGAN
Forkardt
2155 Traversefield Dr
Traverse City, MI 49686
P. 800.544.3823
E. tcsales@forkardt.com

NEW YORK
Hardinge
1 Hardinge Drive
Elmira, NY 14903
P. 800.843.8801
E. info@hardinge.com

OHIO
Ohio Tool Works
1374 Enterprise Parkway (TR 743)
Ashland, OH 44805
P. 419.281.3700
E. sales@ohiotoolworks.com

EUROPE

SWITZERLAND
Hardinge Kellenberger AG
Thannäckerstrasse 22
CH-9403 Goldach
P. 41 71 2429111
E. info@kellenberger.net

GERMANY
Hardinge GmbH
Fichtenhain A 13c
47807 Krefeld
P. 49 2151 49649 10
E. info@hardinge-gmbh.de

J.G. Weisser Söhne GmbH
Johann-Georg-Weisser-Straße 1
78112 St. Georgen
P. +49 7724 881-0
E. info@weisser-web.com

FRANCE
Jones & Shipman SARL
8 Allee des Ginkgos
BP 112-69672
Bron Cedex, France

ASIA

CHINA
Hardinge Machine
(Shanghai) Co. Ltd.
1388 East Kangqiao Road
Pudong, Shanghai 201319
P. 0086 21 3810 8686