

A - A

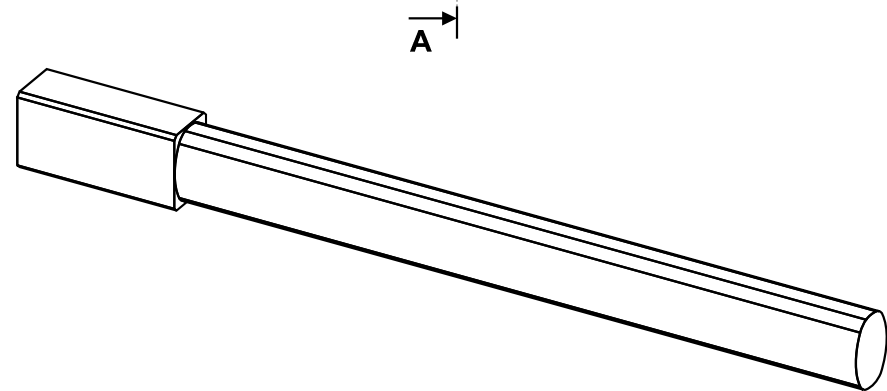

Workpiece		Machine Parameter	
Description:	Drawing punch	Machine Type:	KEL-VARIA
Material:	Alloy tool steel	CNC Control:	Heidenhain
Max. Dimensions [mm]:	∅: 20	Grinding Head Type:	R 1
	Length: 214	Grinding Head Axis:	Fixed Intermediate Section
		No. of Grinding Operations / Clampings:	1

L. Kellenberger & Co. AG
 Heiligkreuzstrasse 28
 CH-9009 St.Gallen
 Switzerland

Phone: +41 (0) 242 91 11
 Fax: +41 (0) 242 92 15
 sales@kellenberger.net
 www.kellenberger.com

Document No. Y100424-651-422e

We reserve all rights in connection with this document.